

XO SELECT



**XO SELECT:**  
The XORELLA custom-designed  
alternative to fit all needs

**XORELLA**

## Many sizes and configurations, allowing the tailoring to any special requirements

**Both, low and high temperature models can be selected with any available loading systems and door-opening design.**

The XO-Steaming Process has many applications in textile manufacturing: Relaxing, twist-setting, pre-shrinking, fixation and stabilization of the textile substrate from fiber to fabric are typical applications of the XO-Steaming Process. XORELLA maintains a vast know-how and data bank for these specific pre-treatments.

For the conditioning and humidification of textile fibers, yarns and fabrics with natural moisture retention, the XO-Steaming Process produces reliable and consistent results with excellent measurable quality improvements.

XO-Steaming is also utilized in the specialty fields, such as glass fiber/yarn, aramid textiles, phytosanitation, digital printing, and more.

Please refer to our application brochures “True Stories” for more detail.

The new XO-Generation uses key components with uncompromised quality and with Engineering Excellence in both, performance and reliability. The treatment vessel and all piping are of world-class stainless steel. The XO-Steaming System is comprised of advanced components and technology. A XORELLA two-stage high performance vacuum pump, and an internationally renowned brand of controller with Swiss engineered software complete the new technology package. Semi- and fully automatic loading systems are available.

The XORELLA sister company in Shenzhen, PRC, manufactures all XORELLA machines according to international quality and safety standards, and with world-class production systems.

Swiss reliability, precision, and craftsmanship are the cornerstones for XORELLA's global service.



# Today, the textile industry recognizes the unique finishing treatment and quality of the **XO-Steaming System.**

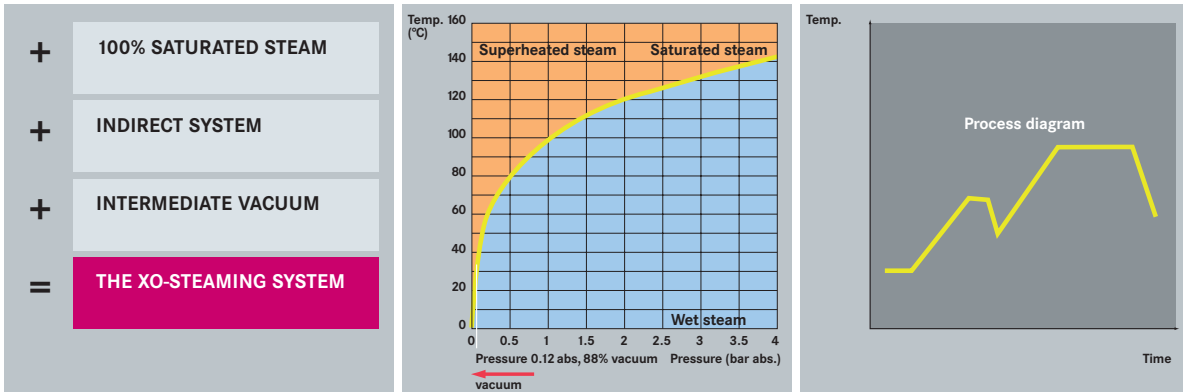

**The XO-Process for vacuum-steaming of textiles uses 100% saturated steam and the renowned XO-Intermediate Vacuum Procedure.**

This is a prerequisite to guarantee even treatment of the textile material and to assure the correctness of the process.

The latest technological advances by XORELLA utilize the above principle with unprecedented low amount of energy usage and exceptional simplicity in machine design.



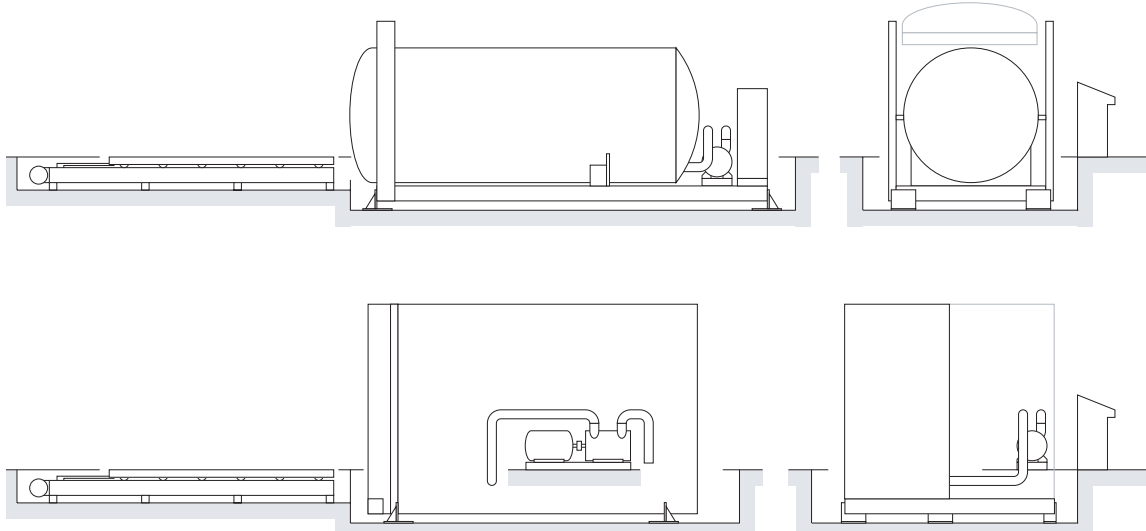

## XO SELECT Custom Design

Configuration	Cylinder	Cube
Operation range	Low and high temperature	Low temperature
Capacity per batch	400–2000 kg	900–4400 kg
diameter/height	1600/1800/2000 mm	2700/2900/3100 mm
width		1400 mm
length	2700–8000 mm	2700–8860 mm
Heating system	Electrical/steam/combined	Electrical/steam/combined
Loading system	Flap gate	Flap gate
	Automatic platform	Automatic platform
	Lifting platform	Lifting platform
	Chain drive	Chain drive
	Roller drive	Roller drive
Flow configuration	1 door/2 doors	1 door/2 doors

All technical data and information are correct at the time of publication, subject to alterations.

# XORELLA

**XORELLA AG**  
 Hardstrasse 41  
 CH-5430 Wettingen  
 Switzerland

**XORELLA (HK) Ltd.**  
 8/F., 22–28 Cheung Tat Road  
 Tsing Yi, Hong Kong

info@xorella.com  
 www.xorella.com

